

Synchronizing multiple ADQ214 with USB connection

1 System build up

The number of channels in an ADQ214 measurement system can be increased by connecting a number of ADQ214 in parallel. The method described here is valid for any number of boards. To start acquisitions simultaneously on all ADQ214 in the system, the same trigger source is used for all cards. The external clock (or the external clock reference) is preferably used to achieve accurate synchronous sampling in all units.

The ADQ214 USB version communicate with the host computer through USB connection. This means that only one ADQ214 can be addressed at the time. The arm trigger command is thus sent to the different units at different times. In measurements with repetitive trigger events, there is a risk that the first unit will be triggered before the second unit is armed. To circumvent this, the GPIO pin is used for broadcasting a trigger enable signal. Two different implementations of such a system are described here.

2 External trigger unit

If an external trigger unit is available (or required), use the system set-up in **Figure 1**. The trigger unit may be synchronized (phase locked) with data and clock, but that is not required. Configure one of the ADQ214 as master and the others as slaves. A master unit uses the GPIO as output for controlling the triggers in slave units. A slave unit uses the GPIO as input for enabling the trigger function.

The operation is then

1. Arm the trigger in the slaves. The trigger is blocked by GPIO signal from the master.
2. Arm the trigger in the master.
3. The trigger in the slaves is released by GPIO signal from the master.
4. The next trigger event triggers all devices.
5. Up-load acquired data from all units.

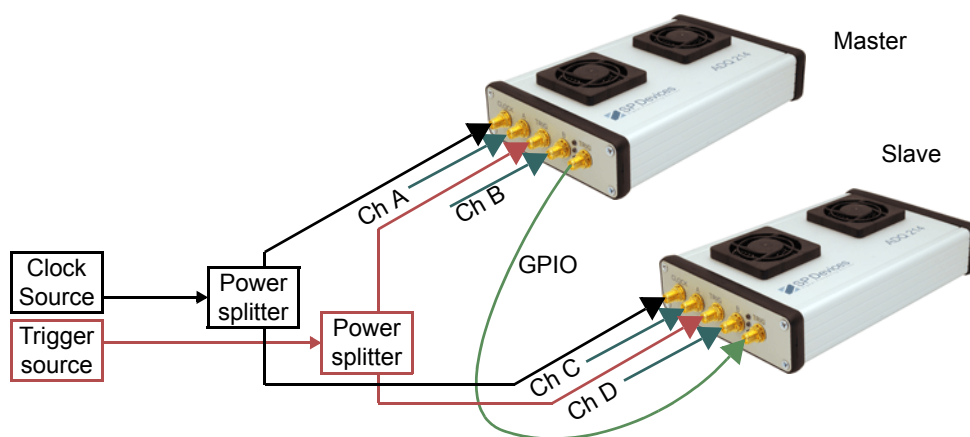

Figure 1: Measurement set-up. External trigger source.

3 Internal trigger unit

If an external trigger unit is not required, use the system set-up in **Figure 2**. This system suitable for measuring repetitive patterns or continuous data streams. Configure one of the ADQ214 as master and the others as slave. A master unit uses the GPIO as output, which triggers all units.

The operation is then:

1. Arm the trigger in all units
2. Trigger all the units by setting GPIO in the master unit.
3. Up-load acquired data from all units.

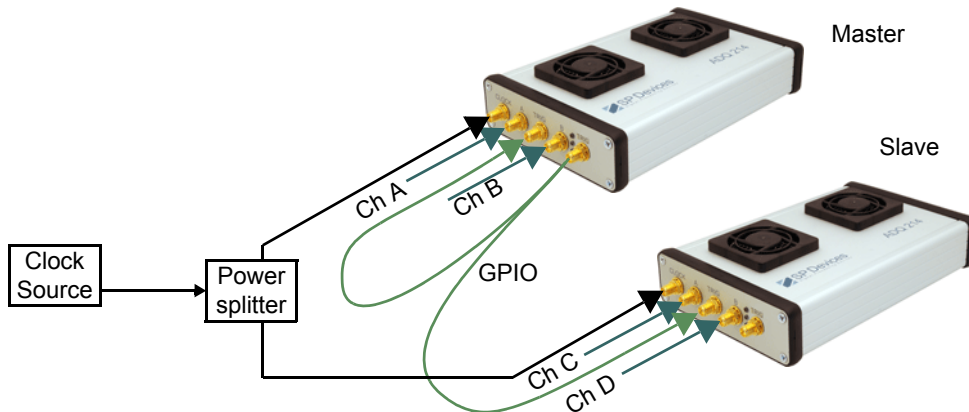

Figure 2: Measurement set-up. Internal trigger source.

4 Example code

The MATLAB example code **ADQ214_4_channels.m** illustrates how to use the synchronization. The output from an evaluation setup is in **Figure 3**. The channel B and D are connected to the same source in order to verify the simultaneous triggering of the two ADQ214.

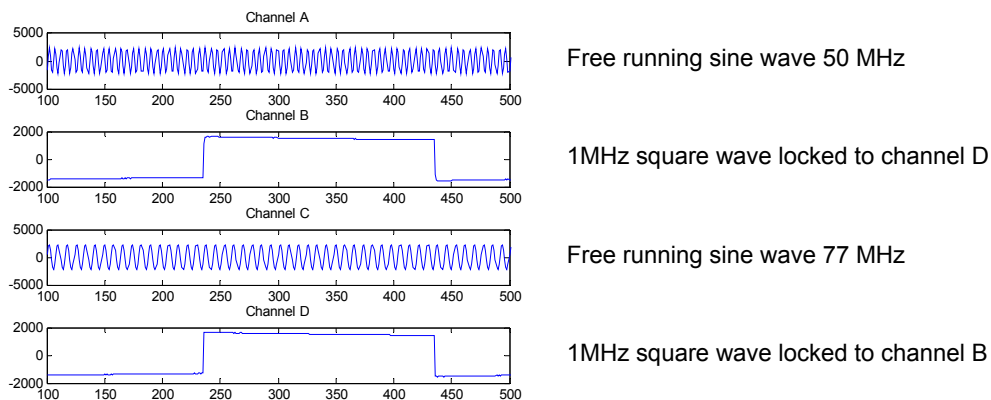

Figure 3: Aligned data example.

5 Compatibility

This application note is applicable on ADQ214 P/N 310-000-000 Rev B with GPIO.

Align data using enhanced trigger accuracy (application note 09-0381).

6 Reference code

MATLAB code **ADQ214_4_channels.m** is available on the product CD.